



CLIMAGUARD Air-To-Air Outdoor Instruction Manual





CLIMAGUARD

Air-to-Air outdoor HeA t exchAngers

tx23, tx33, tx38, tx52 Models

INSTRUCTION MANUAL

TABLE OF CONTENTS

Warranty and Return Policy.....	2
RECEIVING THE HEAT EXCHANGER.....	3
TESTING THE HEAT EXCHANGER.....	3
INSTALLATION INSTRUCTIONS.....	4
PRINCIPLES OF OPERATION.....	4
MAINTENANCE.....	4
Air Movers.....	4
Ambient Air In/Out Screens.....	4
TX23 Series.....	5
TX23 Mounting Cutout Dimensions.....	5
TX23 DC Model Drawing.....	6
TX23 AC Model Drawing.....	6
TX33 Series.....	7
TX33 Mounting Cutout Dimensions.....	7
TX33 DC Model Drawing.....	8
TX33 AC Model Drawing.....	8
TX38 Series.....	9
TX38 Mounting Cutout Dimensions.....	9
TX38 DC Model Drawing.....	10
TX38 AC Model Drawing.....	10
TX52 Series.....	11
TX52 Mounting Cutout Dimensions.....	11
TX52 DC Model Drawing.....	12
TX52 AC Model Drawing.....	12
TX23 Components List.....	13
TX33 Components List.....	13
TX38 Components List.....	13
TX52 Components List.....	13
TX DC Wire Diagram (see label on unit for actual options).....	14
TX23 AC Wire Diagram (see label on unit for actual options).....	15
TX33, TX38, TX52 AC Wire Diagram (see label on unit for actual options).....	15
TROUBLE SHOOTING AC Units.....	16
Basic Trouble Shooting Check List.....	16
TROUBLE SHOOTING DC Units.....	17
Basic Trouble Shooting Check List.....	17

NOTE: Some of the information in this manual may not apply if a special unit was ordered. If additional drawings for a special unit are necessary, they have been inserted. Contact nVent Equipment Protection if further information is required.

WARRANTY AND RETURN POLICY

Visit www.nVentprotect.com/en/hoffman/warranty-information for Product warranty and return policy.

RECEIVING THE HEAT EXCHANGER

Inspect the Heat Exchanger. Check for concealed damage that may have occurred during shipment. Look for dents, scratches, loose assemblies, etc. Damage evident upon receipt should be noted on the freight bill. Damage should be brought to the attention of the delivering carrier -- NOT to nVent Equipment Protection -- within 15 days of delivery. Save the carton and packing material and request an inspection. Then file a claim with the delivering carrier.

nVent Equipment Protection cannot accept responsibility for freight damages; however, we will assist you in any way possible.

TESTING THE HEAT EXCHANGER

TEST FOR FUNCTIONALITY BEFORE MOUNTING THE HEAT EXCHANGER TO THE ENCLOSURE.

Refer to nameplate for proper electrical current requirements, and then connect power cord or wire the unit to a properly grounded power supply using copper conductors only. Power supply wiring should be restrained after field installation to ensure no contact with internal fan. Minimum circuit ampacity should be at least 125% of the amperage shown on the nameplate for the appropriate model. No other equipment should be connected to this circuit to prevent overloading.

Operate the heat exchanger for several minutes. No excessive noise or vibration should be evident during this run period. Ambient air mover may not be energized at temperatures low enough to not require cooling. On DC powered units, air movers may not always be running at full speed.

INSTALLATION INSTRUCTIONS

1. Inspect heat exchanger. Verify functionality before mounting the heat exchanger, see TESTING THE HEAT EXCHANGER on page 3.
2. Determine if the unit is to be surface or recess mounted. Using the appropriate cutout dimensions shown in this manual, prepare the enclosure opening for either surface or recess mounting.
3. Using the gasket kit provided, install gaskets to heat exchanger.
4. Mount heat exchanger on enclosure using mounting screws provided. Torque screws to 25 in-lbs (2.82 Nm).
5. Refer to unit nameplate for electrical requirements. Connect the power cord to a properly grounded power supply. Use of an extension cord is not recommended. Electrical circuit should be fused with slow blow or HACR circuit breaker.

PRINCIPLES OF OPERATION

Operating the heat exchanger below the minimum ambient temperature or above the maximum ambient temperatures indicated on the nameplate voids all warranties.

It is recommended that the warranty section of this manual be read in order to familiarize yourself with parameters of restricted operation.

MAINTENANCE

AIR MOVERS

Air mover motors require no maintenance. All bearings are lubricated during manufacturing for the life of the motor.

If the ambient air mover should fail, it is not necessary to remove the heat exchanger from the cabinet or enclosure to replace it. The ambient air mover is mounted on a bulkhead and is easily accessible by removing the front cover.

Caution! Operation of the heat exchanger in areas containing airborne caustics or chemicals can rapidly deteriorate aluminum cores and air movers. Contact nVent Equipment Protection for special recommendations.

AMBIENT AIR IN/OUT SCREENS

In dirty environments, the bug screens on the front cover may need to be cleaned periodically to maintain adequate cooling performance. The front cover should be removed from the heat exchanger and set aside for cleaning with water, air or scrubbed clean with a brush.

TX23 SERIES
25 Watts/°C (14 Watts/°F)

Model	Voltage	Hz	Full Load Amps	Phase	Maximum Temperature (°C/°F)	Minimum Temperature (°C/°F)	Shipping Weight (lb./kg)
TX23-1424-XXX	24VDC		3.4		65/149	-40/-40	30/13.6
TX23-1448-XXX	48VDC		1.8		65/149	-40/-40	30/13.6
TX23-1416-XXX	115VAC	50/60	TBD	1	65/149	-40/-40	30/13.6
TX23-1426-XXX	230VAC	50/60	TBD	1	65/149	-40/-40	30/13.6

XXX will be replaced with a three-digit number designating all desired options. Consult the factory for specific model numbers.

TX23 MOUNTING CUTOUT DIMENSIONS

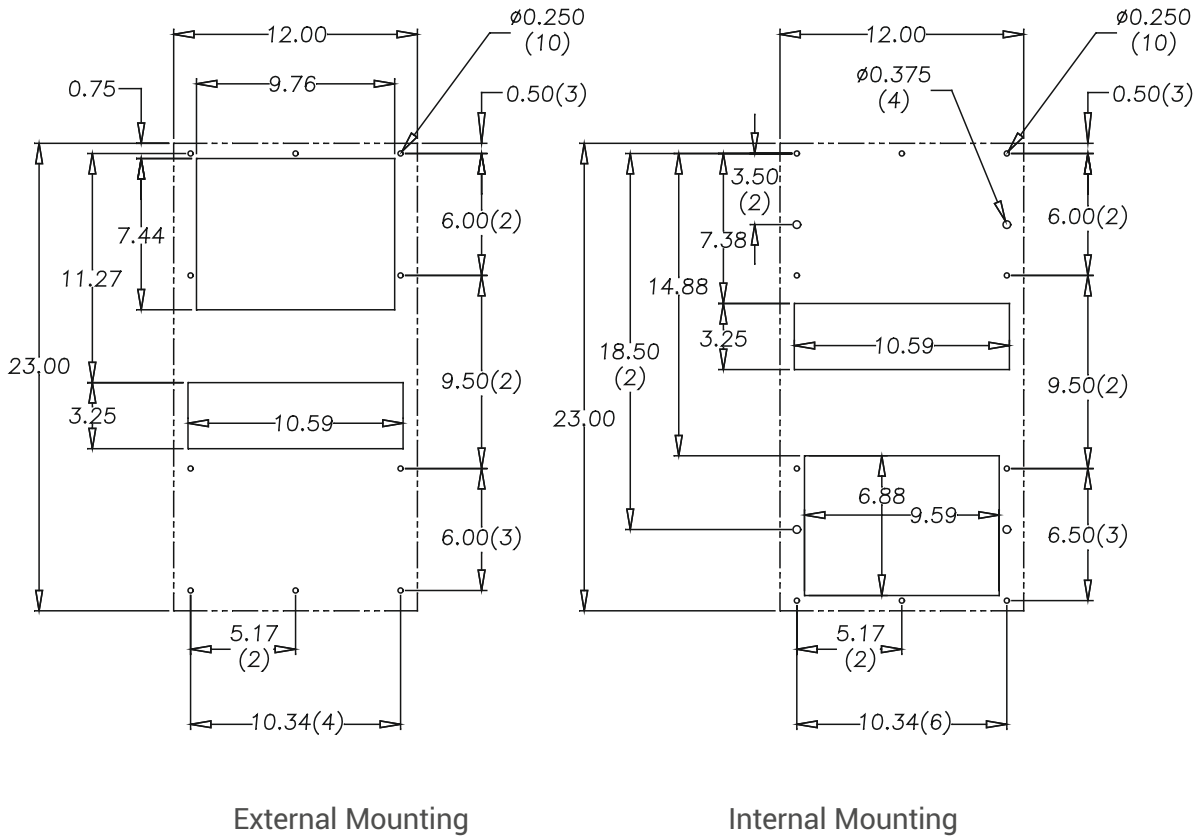

External Mounting

Internal Mounting

CUTOUT INSTRUCTIONS
(As viewed from outside of enclosure)

NOTE: Dashed lines represent heat exchanger.

TX23 DC MODEL DRAWING

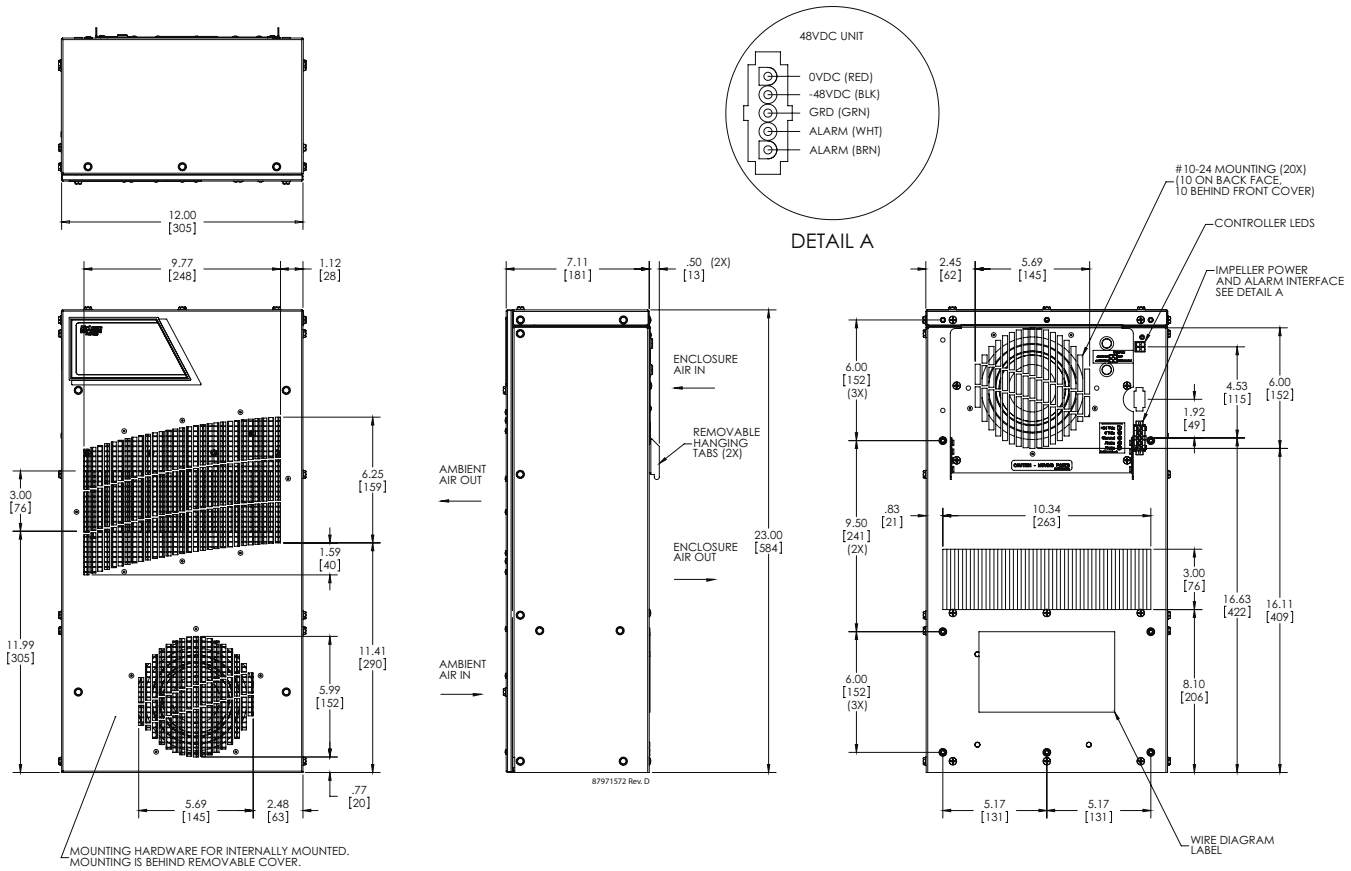

TX23 AC MODEL DRAWING

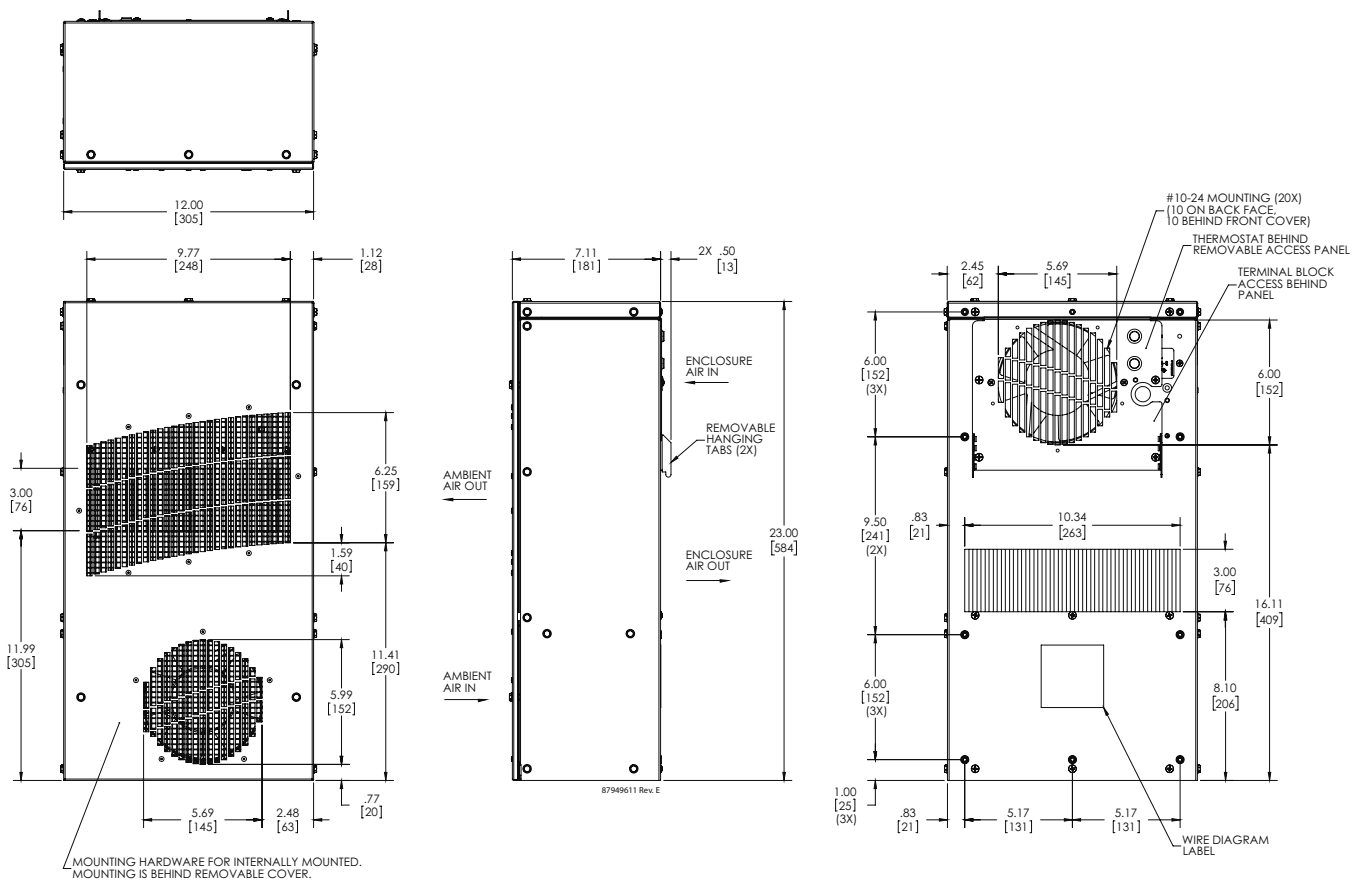

TX33 SERIES
50 Watts/°C (28 Watts/°F)

Model	Voltage	Hz	Full Load Amps	Phase	Maximum Temperature (°C/°F)	Minimum Temperature (°C/°F)	Shipping Weight (lb./kg)
TX33-2824-XXX	24VDC		3.4		65/149	-40/-40	45/20.4
TX33-2848-XXX	48VDC		1.8		65/149	-40/-40	45/20.4
TX33-2816-XXX	115VAC	50/60	TBD	1	65/149	-40/-40	45/20.4
TX33-2826-XXX	230VAC	50/60	TBD	1	65/149	-40/-40	45/20.4

XXX will be replaced with a three-digit number designating all desired options. Consult the factory for specific model numbers.

TX33 MOUNTING CUTOUT DIMENSIONS

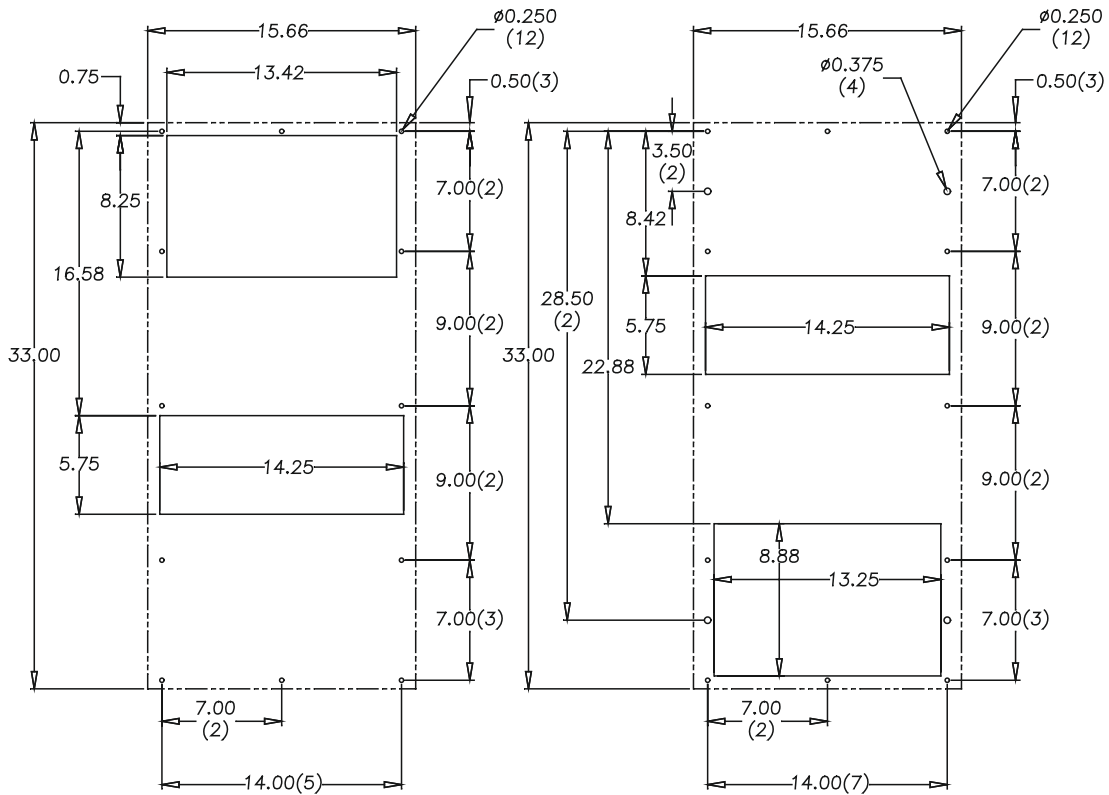

External Mounting

Internal Mounting

CUTOUT INSTRUCTIONS
(As viewed from outside of enclosure)

NOTE: Dashed lines represent heat exchanger.

TX33 DC MODEL DRAWING

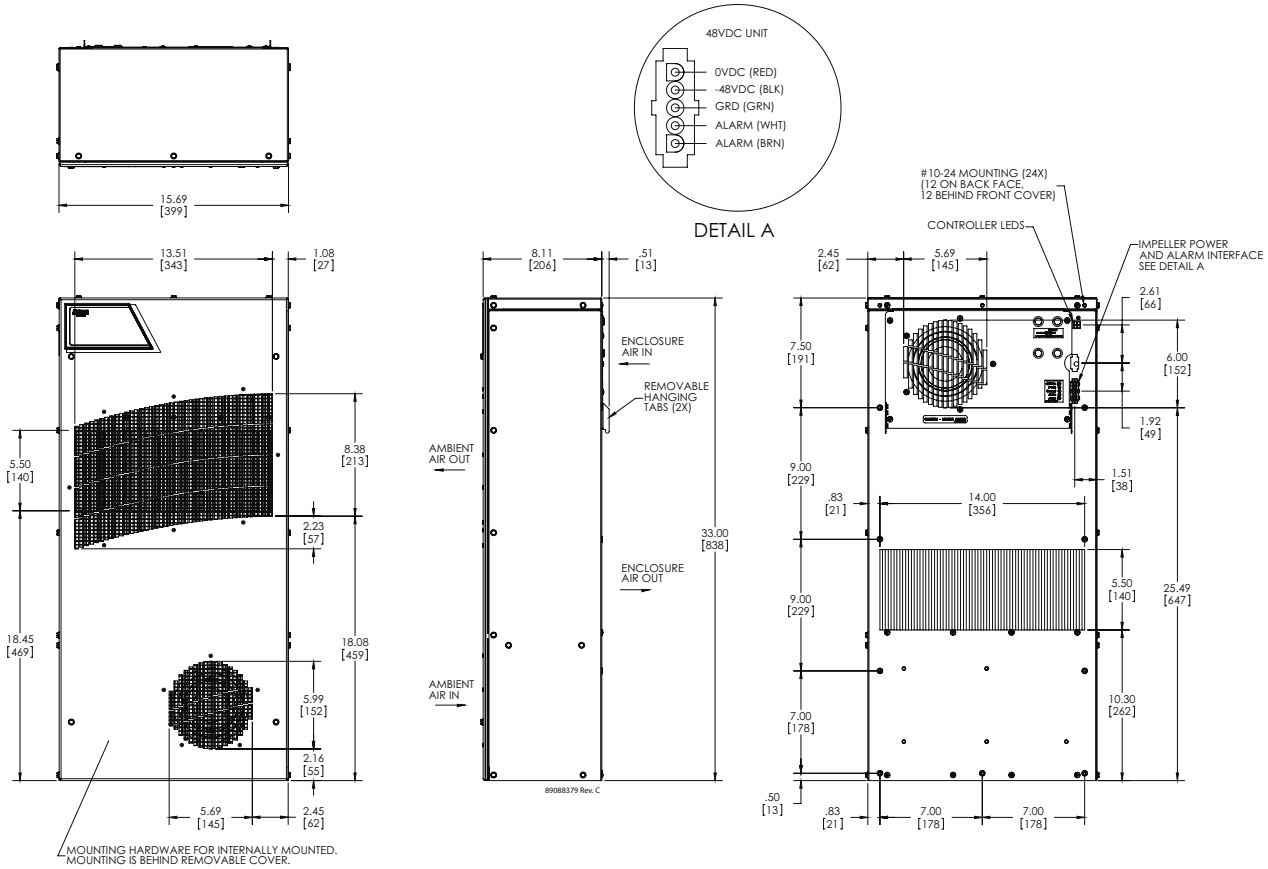

TX33 AC MODEL DRAWING

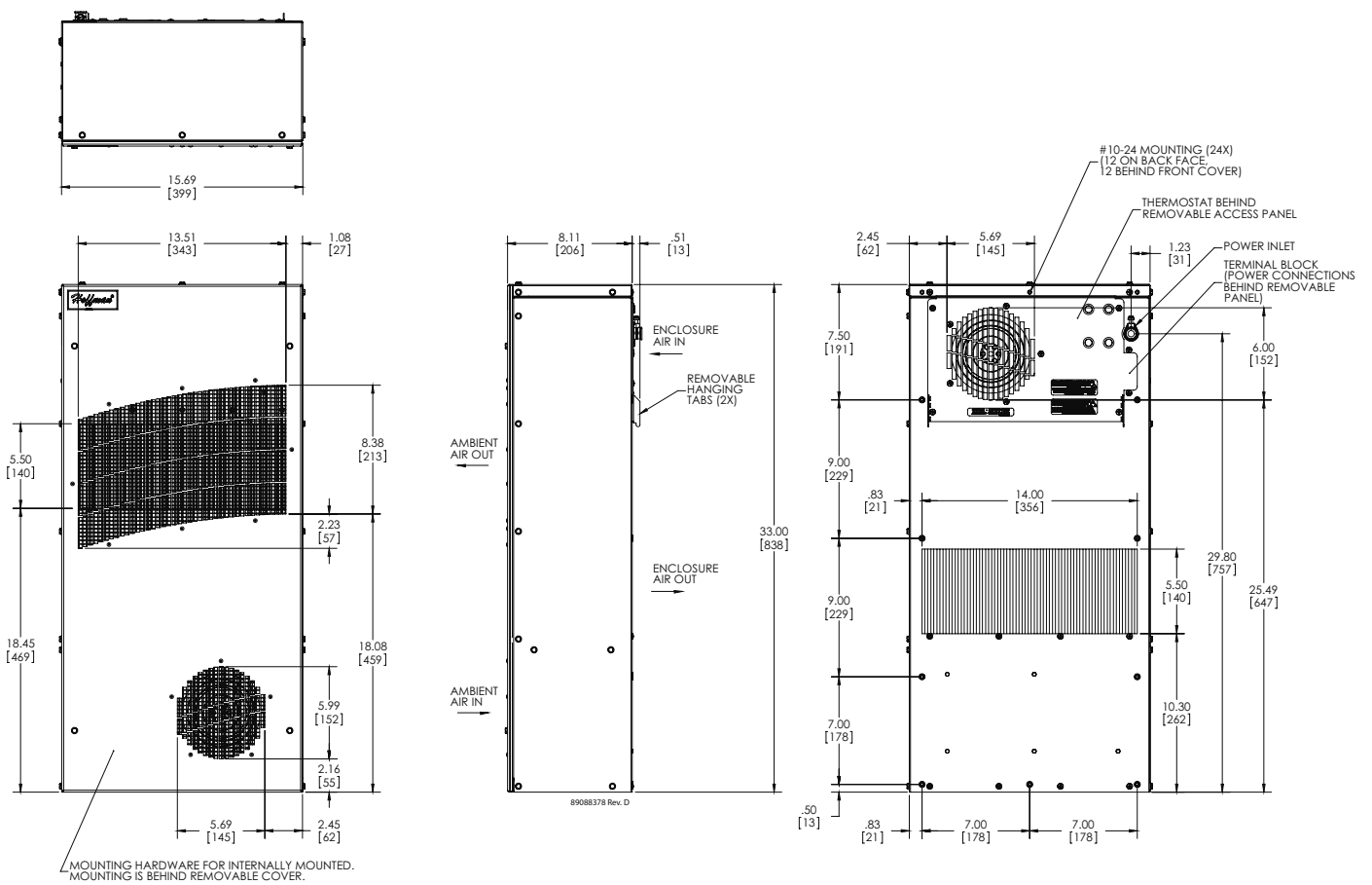

TX38 SERIES
100 Watts/°C (56 Watts/°F)

Model	Voltage	Hz	Full Load Amps	Phase	Maximum Temperature (°C/°F)	Minimum Temperature (°C/°F)	Shipping Weight (lb./kg)
TX38-5624-XXX	24VDC		8.6		65/149	-40/-40	66/30
TX38-5648-XXX	48VDC		5.8		65/149	-40/-40	66/30
TX38-5616-XXX	115VAC	50/60	TBD	1	65/149	-40/-40	66/30
TX38-5626-XXX	230VAC	50/60	TBD	1	65/149	-40/-40	66/30

XXX will be replaced with a three-digit number designating all desired options. Consult the factory for specific model numbers.

TX38 MOUNTING CUTOUT DIMENSIONS

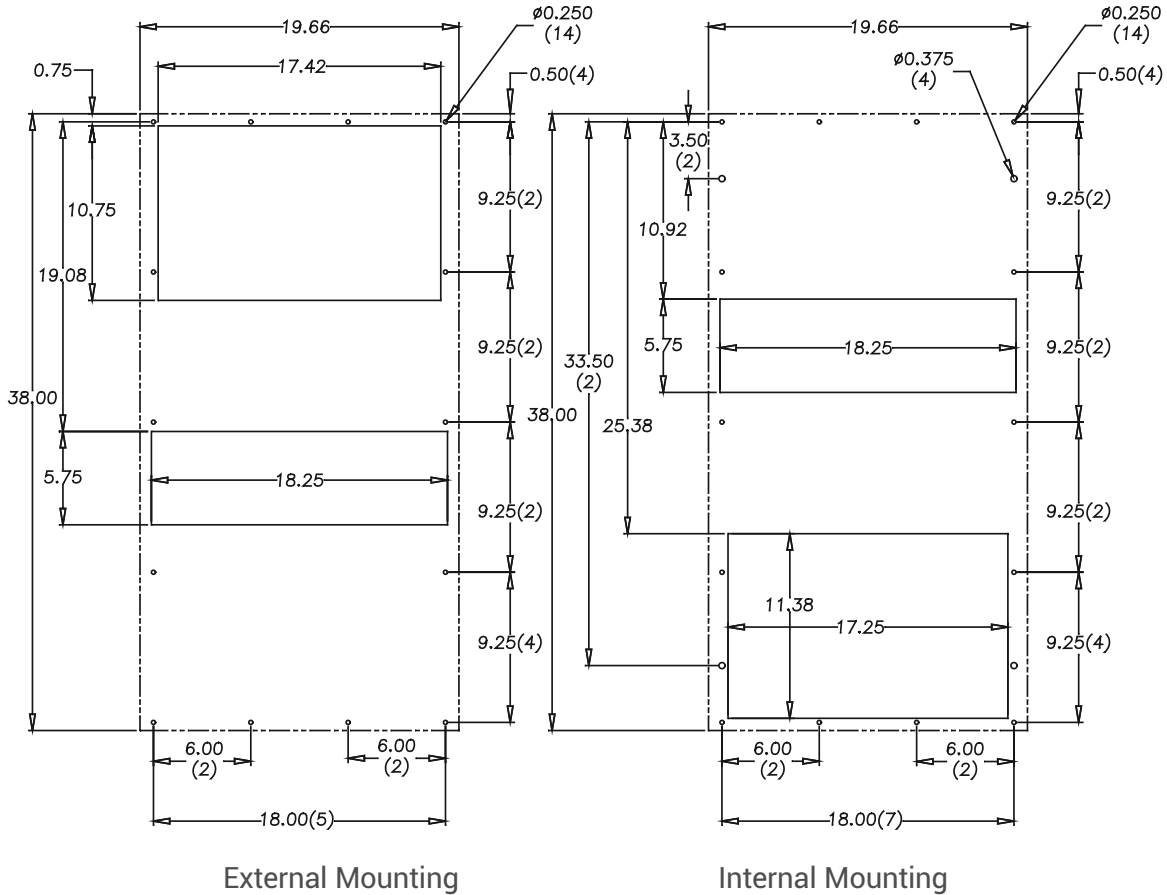

CUTOUT INSTRUCTIONS
(As viewed from outside of enclosure)

NOTE: Dashed lines represent heat exchanger.

TX52 DC MODEL DRAWING

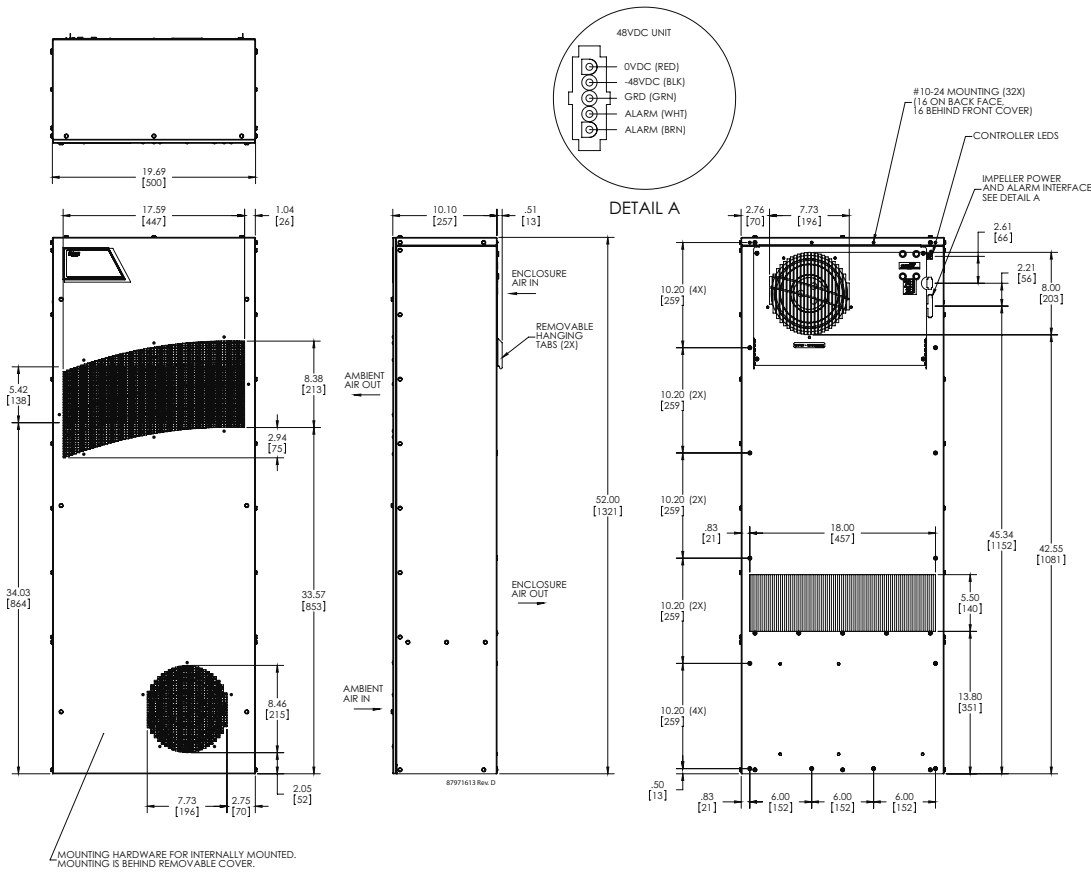

TX52 AC MODEL DRAWING

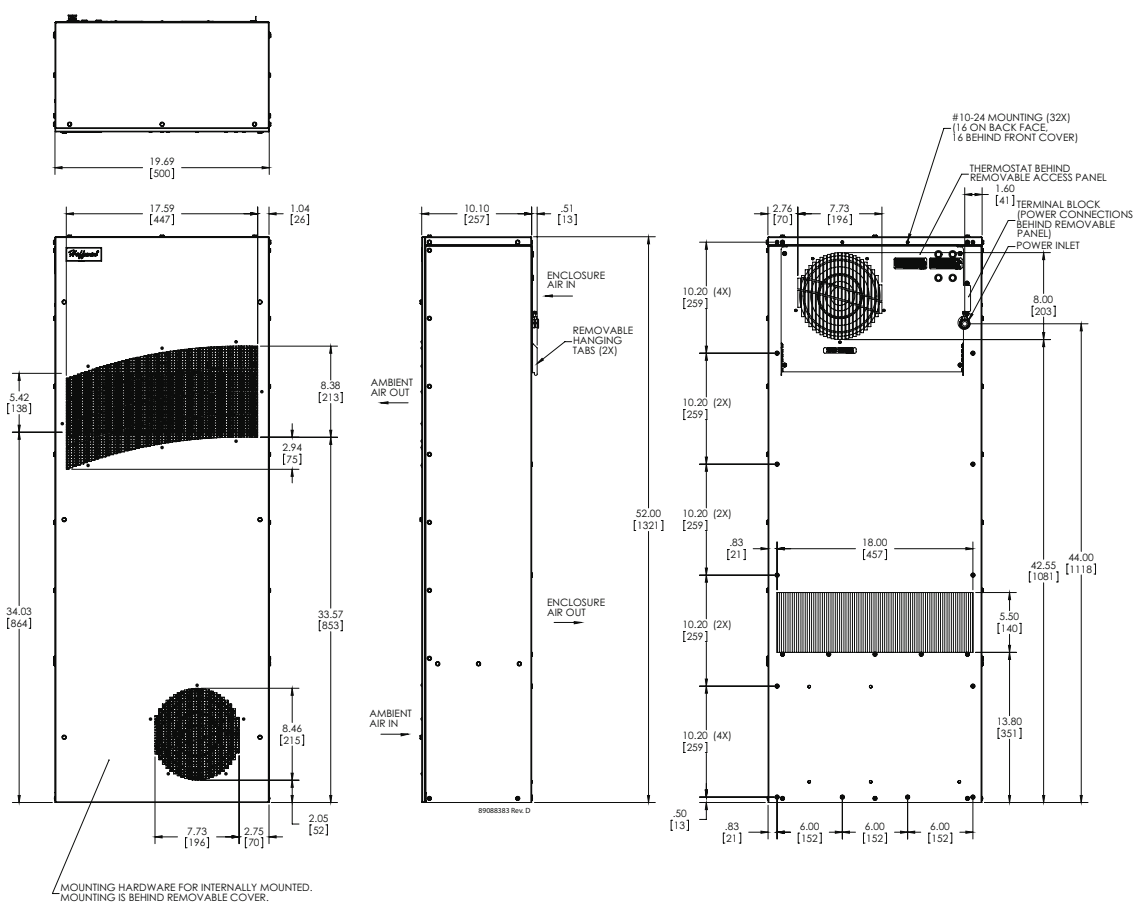

TX23 COMPONENTS LIST

Part Description	Part Number			
	24VDC	48VDC	115VAC	230VAC
Air Movers	10-1091-64	10-1091-55	12-1012-01	12-1012-02
Controller, Generic (may vary w/options)	E117E004	E117E004	NA	NA
Thermostat	NA	NA	10-1061-16	10-1061-16
Service Cord / Harness	09-3001-89	09-3001-89	52-6035-138	52-6035-139

TX33 COMPONENTS LIST

Part Description	Part Number			
	24VDC	48VDC	115VAC	230VAC
Air Movers	10-1091-64	10-1091-55	10-1091-130	10-1091-131
Controller, Generic (may vary w/options)	E117E004	E117E004	NA	NA
Thermostat	NA	NA	10-1061-16	10-1061-16
Capacitors	NA	NA	S-1353-1	52-6084-02
Service Cord / Harness	09-3001-89	09-3001-89	N/A	N/A

TX38 COMPONENTS LIST

Part Description	Part Number			
	24VDC	48VDC	115VAC	230VAC
Air Movers	10-1091-12	10-1091-109	10-1091-132	10-1091-133
Controller, Generic (may vary w/options)	E117E000	E117E000	NA	NA
Thermostat	NA	NA	10-1061-16	10-1061-16
Capacitors	NA	NA	52-6031-03	52-6084-05
Service Cord / Harness	09-3001-89	09-3001-89	N/A	N/A

TX52 COMPONENTS LIST

Part Description	Part Number			
	24VDC	48VDC	115VAC	230VAC
Air Movers	10-1091-125	10-1091-126	10-1091-134	10-1091-135
Controller, Generic (may vary w/options)	E117E002	E117E006	NA	NA
Thermostat	NA	NA	10-1061-16	10-1061-16
Capacitors	NA	NA	52-6031-03	52-6084-05
Service Cord / Harness	09-3001-96	09-3001-89	N/A	N/A

TX DC WIRE DIAGRAM (SEE LABEL ON UNIT FOR ACTUAL OPTIONS)

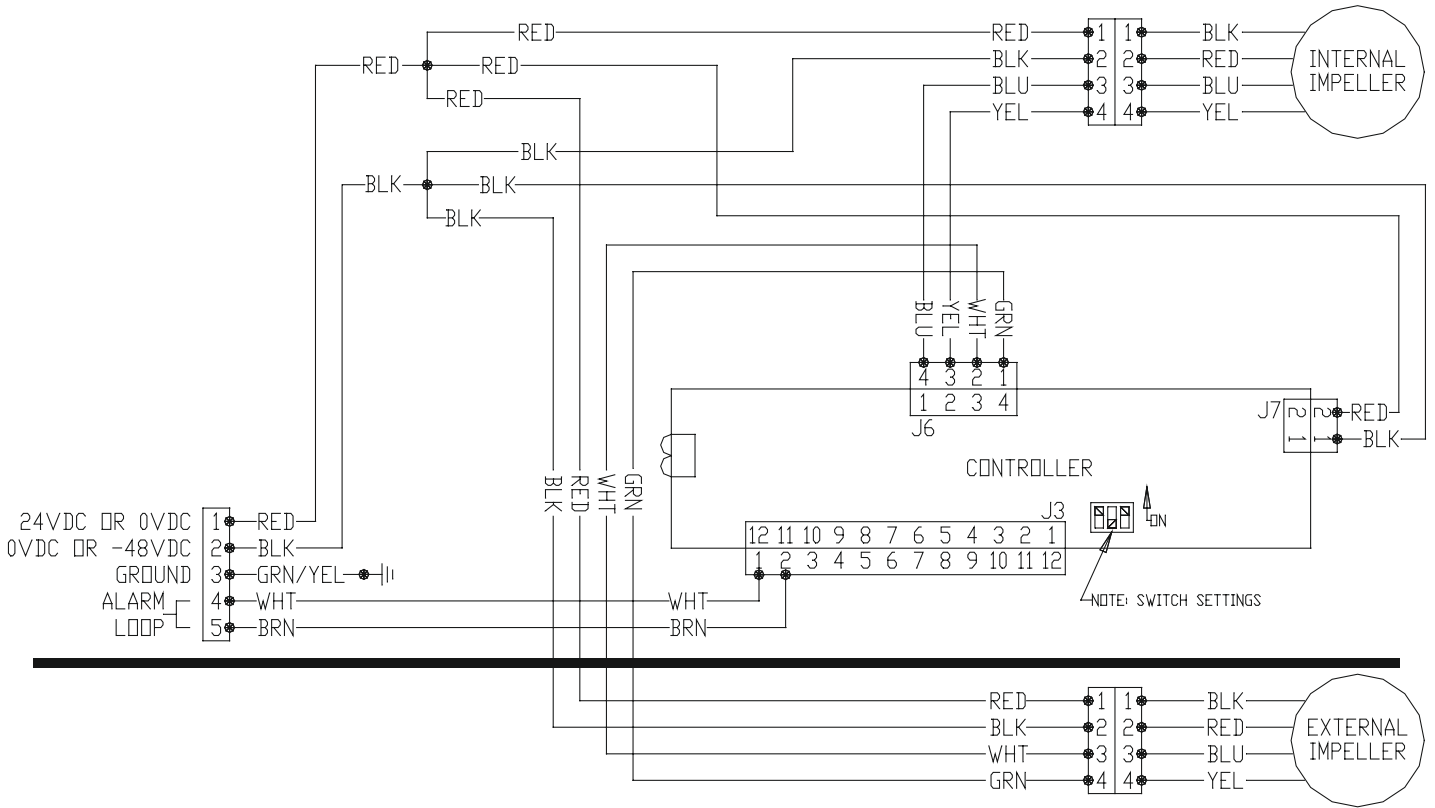

TX23 AC WIRE DIAGRAM (SEE LABEL ON UNIT FOR ACTUAL OPTIONS)

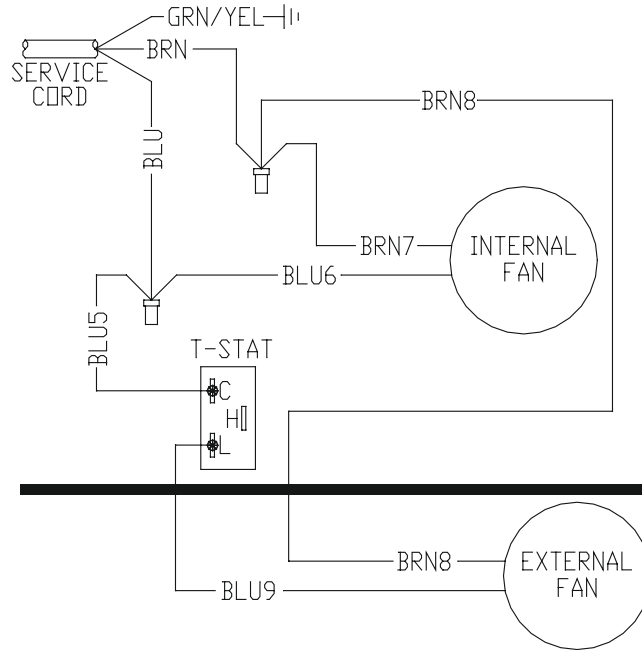

TX33, TX38, TX52 AC WIRE DIAGRAM (SEE LABEL ON UNIT FOR ACTUAL OPTIONS)

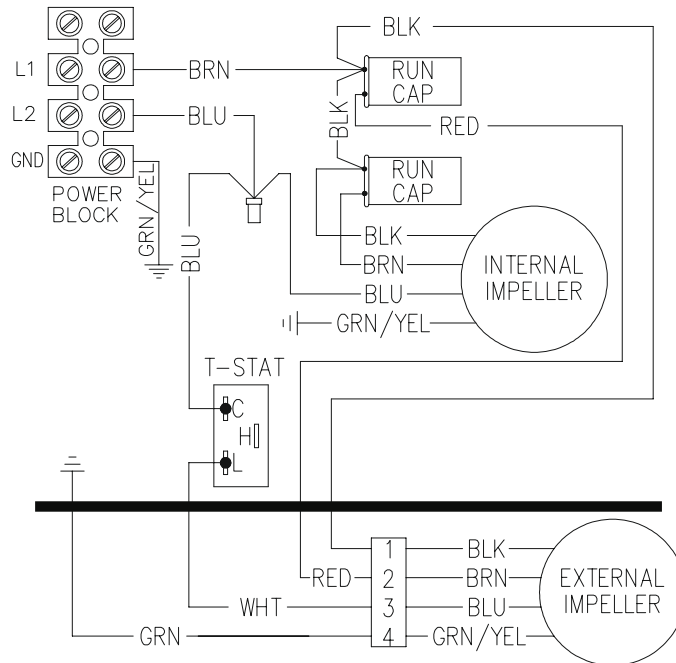

89105555 Rev.A

TROUBLE SHOOTING AC UNITS

BASIC TROUBLE SHOOTING CHECK LIST

1. Check manufacturer's nameplate located on the unit for correct power supply.
2. Unit blows fuses or breakers.

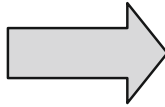
<ul style="list-style-type: none"> • Under sized fuse/breaker or not time delayed • Short in system 		Repair or Replace defective part
---	--	---

3. Turn on power to the unit. The enclosure air mover should come on. Is there airflow?

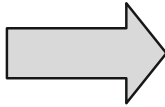
YES, proceed to step 4.		
NO, possible problem:		
<ul style="list-style-type: none"> • Open motor winding • Stuck air mover motor • Obstructed wheels/blades 		Repair or Replace defective part

4. Check thermostat setting? Adjust thermostat to the lowest setting. This should turn both air movers on. Did both air movers come on when the thermostat was turned down?

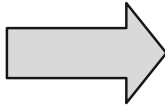
YES, proceed to step 5.		
NO, possible problem:		
<ul style="list-style-type: none"> • Defective thermostat 		Replace part

5. Are both air movers running? If not, the unit will not cool properly.
6. Check ambient air mover for airflow. Is there airflow?

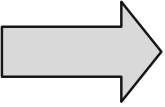
YES, proceed to step 7.		
NO, possible problem:		
<ul style="list-style-type: none"> • Defective thermostat • Open motor winding • Stuck air mover motor • Obstructed wheels/blades 		Repair or Replace defective part

7. To check for a bad thermostat, turn off power to the unit. Remove access cover and place both thermostat wires onto one terminal (replace access cover for safety). This will bypass the switch in the thermostat. Turn on power to the unit and if both air movers come on, the thermostat needs to be replaced.

For additional technical information (i.e., amp draw, temperatures) , contact nVent Equipment Protection at 800-896-2665.

TROUBLE SHOOTING DC UNITS

BASIC TROUBLE SHOOTING CHECK LIST

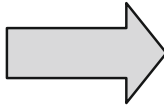

1. Check manufacturer's nameplate located on the unit for correct power supply.
2. Unit blows fuses or breakers.

<ul style="list-style-type: none"> • Under sized fuse/breaker or not time delayed • Short in system 		Repair or Replace defective part
---	--	---

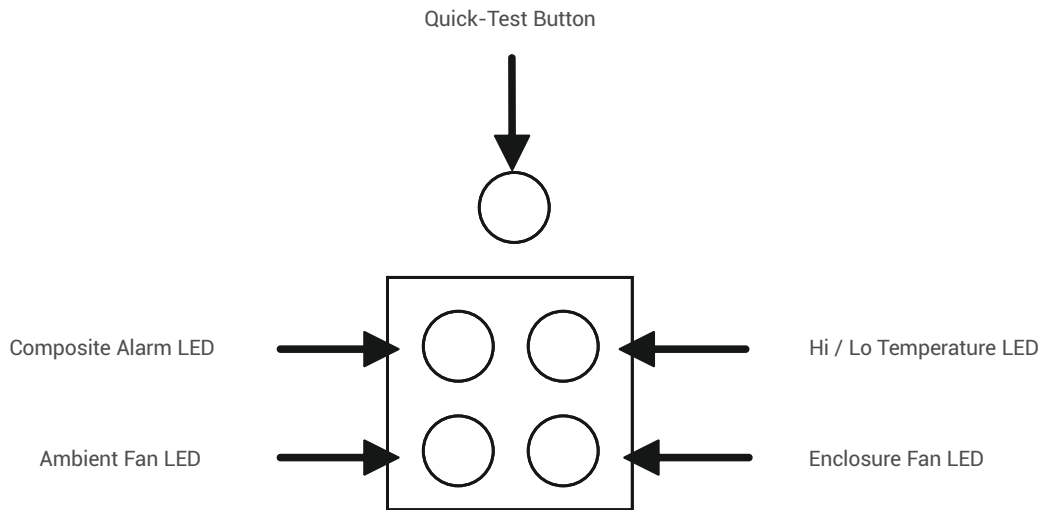
3. Turn on power to the unit.
4. Press the Quick-Test button (located above the LED's on the enclosure side of the unit). The unit will cycle through a series of self-diagnostic tests to verify proper operation of components.

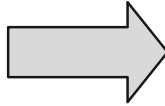
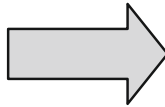

5. Do all LED's clear to GREEN following the self test? RED indicates a fault.

YES, unit is working properly.			
NO, identify which alarm is activated: Note the Composite Alarm LED will also light if any other alarm activates.			
<ul style="list-style-type: none"> • Ambient air mover OR Enclosure air mover 		<ul style="list-style-type: none"> • Open motor winding • Stuck air mover motor • Obstructed blades 	Repair or Replace defective part
<ul style="list-style-type: none"> • Hi / Lo Temperature 		<ul style="list-style-type: none"> • If the enclosure temperature is outside the nameplate temperature range, the Hi / Lo Temperature alarm will activate. 	
<ul style="list-style-type: none"> • Composite Alarm Only 		<ul style="list-style-type: none"> • Controller Temperature Sensor Failure 	Repair or Replace defective part

For additional technical information (i.e., amp draw, temperatures) , contact nVent Equipment Protection at 800-896-2665.

NOTES

NOTES



nVent
2100 Hoffman Way
Anoka, MN 55303 USA
☎ +1.763.422.2211
📠 +1.763.576.3200
nVent.com



+44 (0)121 544 6808

| info@cnet-is.co.uk

**C-NET Industrial Solutions
Limited**

Suite 12, Sandwell Business Centre
Oldbury Road
Smethwick
B66 1NN
United Kingdom