



**cnetindustrial**

**PWI\_PWS 6052 εCOOL  
AIR\_WATER HEAT  
EXCHANGER 500 W**

**Pfannenberg**  
ELECTRO-TECHNOLOGY FOR INDUSTRY



# PWI/PWS 6052

## ECOOL AIR/WATER HEAT EXCHANGER 500 W

**PWI:** for partially recessed mounting in the door or side

**PWS:** for outer mounting on the door or side

- offers the highest degree of safety and energy efficiency
- cut-out compatible with ECOOL system e.g. for air/air heat exchanger and cooling units
- easy mounting with click and fit system for partially sunk-in version PWI
- maintenance-free
- integrated thermostat and solenoid valve for temperature control
- integrated temperature monitoring with alarm contact



PRODUCT		PWI 6052		PWS 6052		
ARTICLE NO.		12891201055	12891204055	12881201055	12881204055	Unit
<b>DATA</b>						
Rated voltage ±10 %		AC 50   60	AC 60	AC 50   60	AC 60	Hz
		230	115	230	115	V
Cooling capacity @ 200 l/h	W10/A35	500				W
Power consumption	W10/A35	68   78	70	68   78	70	
Current consumption	W10/A35	0.3   0.34	0.6	0.3   0.34	0.6	A
Starting current	W10/A35	0.4	0.7	0.4	0.7	
Unimpeded airflow (free flow)	internal	520				m³/h
Pre fuse T		2				A
Type of connection	electro	spring-type terminal included with plug				
	fluid	13 mm hose nozzle   other connectors on request				
Noise level according to EN ISO 3741		≤ 48				dB (A)
Weight (without packaging)		10.5		11		kg
Ambient temperature range		> +1 ... +70   > +34 ... +158				
Control range (adjustable)		+8 ... +50   +47 ... +122; factory setting +35   +95				°C   °F
Water inlet temperature		> +2 ... +35   > +34 ... +95				
Permissible operating pressure		max. 10				bar
Duty cycle		100				%
Condensate management		condensate drain				
Protection system according to EN 60529	IP 55	towards the electrical enclosure if used as intended by the manufacturer				
Design	housing	galvanised steel   electrostatically powder coated (200 °C)   stainless steel on request				
	heat exchanger	copper pipe with aluminium fins   stainless steel piping on request				
Colour	cover	RAL 7035   different colours available on request				

ACCESSORIES	Piece	ARTICLE NUMBER
External condensate evaporation system	1	18314000001
Condensate bottle	1	18314000100

For additional models, options and voltages visit [www.pfannenber.com](http://www.pfannenber.com) or contact us directly.



### Cooling capacity performance curves

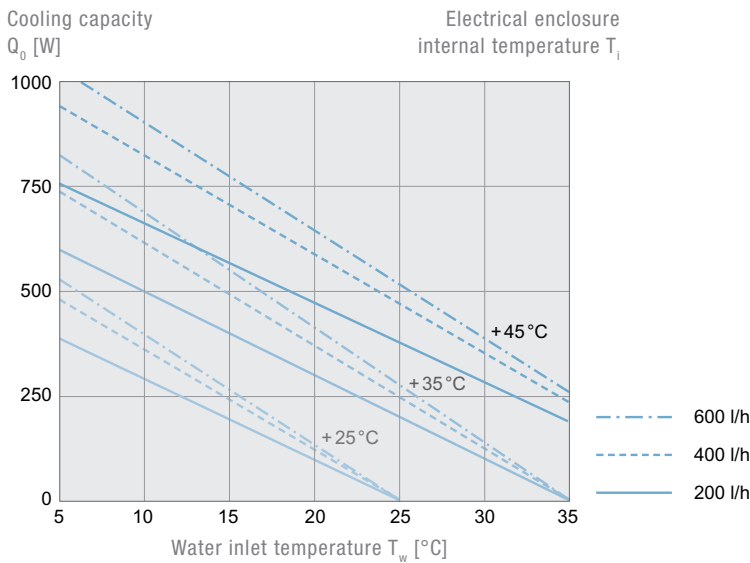

### Pressure loss performance curve

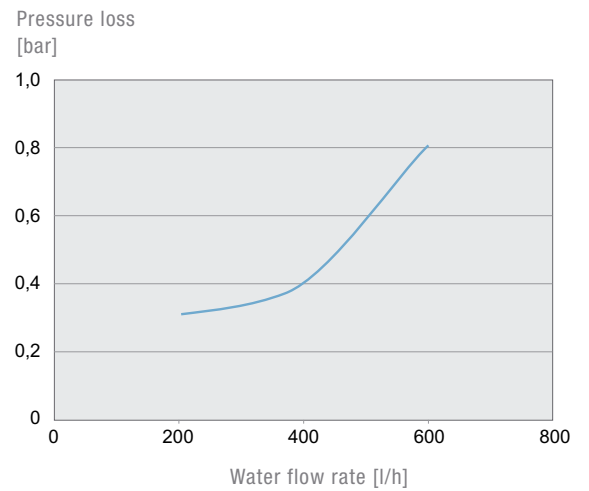

### Dimensions

PWI	X	Y	Z1	Z2	K	L
mm	380	615	82	60	577	350

PWI variants partially recessed by 60 mm after installation

PWS	X	Y	Z	A	B	C	D	E	F	G
mm	380	622.5	142	472	285	272	150	288	40	300

Mounting holes  $\varnothing$  8 mm and cut-out radii R10

PWI 6052	PWS 6052
----------	----------

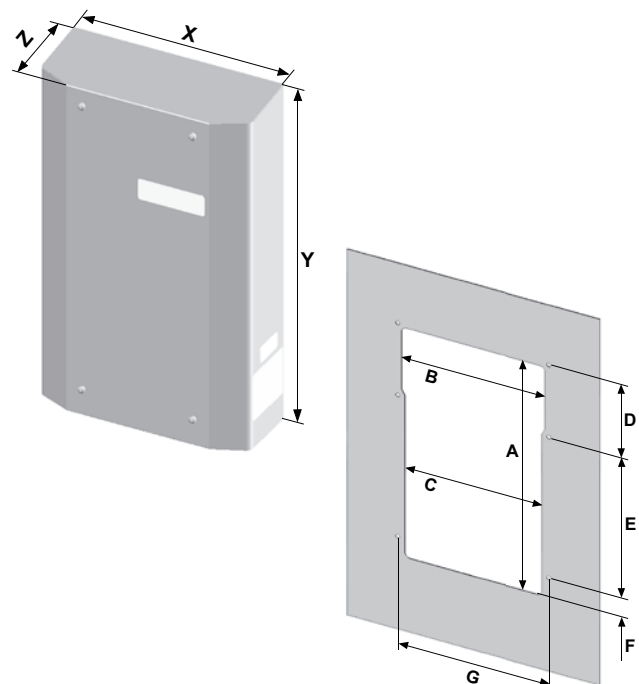
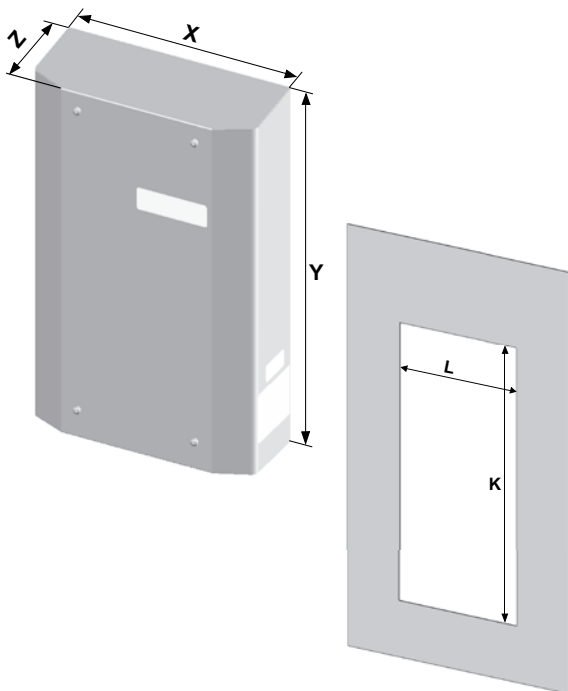



+44 (0)121 544 6808

| [info@cnet-is.co.uk](mailto:info@cnet-is.co.uk)

**C-NET Industrial Solutions  
Limited**

Suite 12, Sandwell Business Centre  
Oldbury Road  
Smethwick  
B66 1NN  
United Kingdom