



# Air-To-Air Indoor Instruction Manual





# CLIMAGUARD

Air-To-Air indoor HeAT exchAngers

All Models

# INSTRUCTION MANUAL

## TABLE OF CONTENTS

WARRANTY AND RETURN POLICY.....	2
F-GAS INFORMATION.....	2
FEATURES.....	3
Design Data.....	3
Dimensional Drawings.....	4
Drawing Variables.....	5
Cutouts.....	6
Cutouts.....	7

## WARRANTY AND RETURN POLICY

<https://hoffman.nvent.com/en/hoffman/warranty-information>

## F-GAS INFORMATION

	XR200416XXX XR200426XXX	XR290816XXX XR290826XXX
Refrigerant Kühlmittel Chłodziwo	R134a	R134a
GWP	1430	1430
Factory Charge Füllmenge durch Hersteller Opłata Fabryczna	113 Grams 113 Gramm 113 Gramów	156 Grams 156 Gramm 156 Gramów
CO <sub>2</sub> Equivalent CO <sub>2</sub> Equivalent CO <sub>2</sub> Ekwilalent	0.16 Tons 0,16 Tonnen 0,16 Tony	0.22 Tons 0,22 Tonnen 0,22 Tony

## FEATURES

- The ProAir Heat Exchangers use our unique counter-flow aluminum core for high efficiency and high performance heat transfer except for the XR20 and XR29-08 which uses a modified heat pipe core.
- Top quality impellers make these units run quietly and with increased reliability.
- Streamlined aesthetics with no visible mounting rails or fasteners. The slim design allows for mounting to narrow or shallow enclosures.
- Filter-less design for low maintenance and easy cleaning.
- Mounts front, side, top, outside, vertically or horizontally.
- Four fasteners allow simple removal of front cover for easy access.
- Each unit is 100% functionally tested.

Note: To avoid cross-threading mounting inserts, start bolts by hand before tightening with a wrench or ratchet driver.

## DESIGN DATA

Model	Voltage	Hz	Full Load Amps	Max Ambient Temperature (°F/°C)	Shipping Weight (lb./kg)
XR20-0416-012	115	50/60	0.6	155/68	12 lb./5.44 kg
XR20-0426-012	230	50/60	0.6	155/68	12 lb./5.44 kg
XR29-0816-012	115	50/60	0.6	155/68	27 lb./12.25 kg
XR29-0826-012	230	50/60	0.6	155/68	27 lb./12.25 kg
XR29-1816-012	115	50/60	1.0	155/68	34 lb./15.42 kg
XR29-1826-012	230	50/60	1.0	155/68	34 lb./15.42 kg
XR47-2416-012	115	50/60	1.5	155/68	51 lb./23.13 kg
XR47-2426-012	230	50/60	1.5	155/68	51 lb./23.13 kg
XR47-3516-012	115	50/60	1.5	155/68	63 lb./28.58 kg
XR47-3526-012	230	50/60	1.5	155/68	63 lb./28.58 kg
XR60-5516-012	115	50/60	6.7	155/68	91 lb./41.28 kg
XR60-5526-012	230	50/60	6.7	155/68	91 lb./41.28 kg
XR60-8416-012	115	50/60	6.7	155/68	115 lb./52.16 kg
XR60-8426-012	230	50/60	6.7	155/68	115 lb./52.16 kg

# DIMENSIONAL DRAWINGS

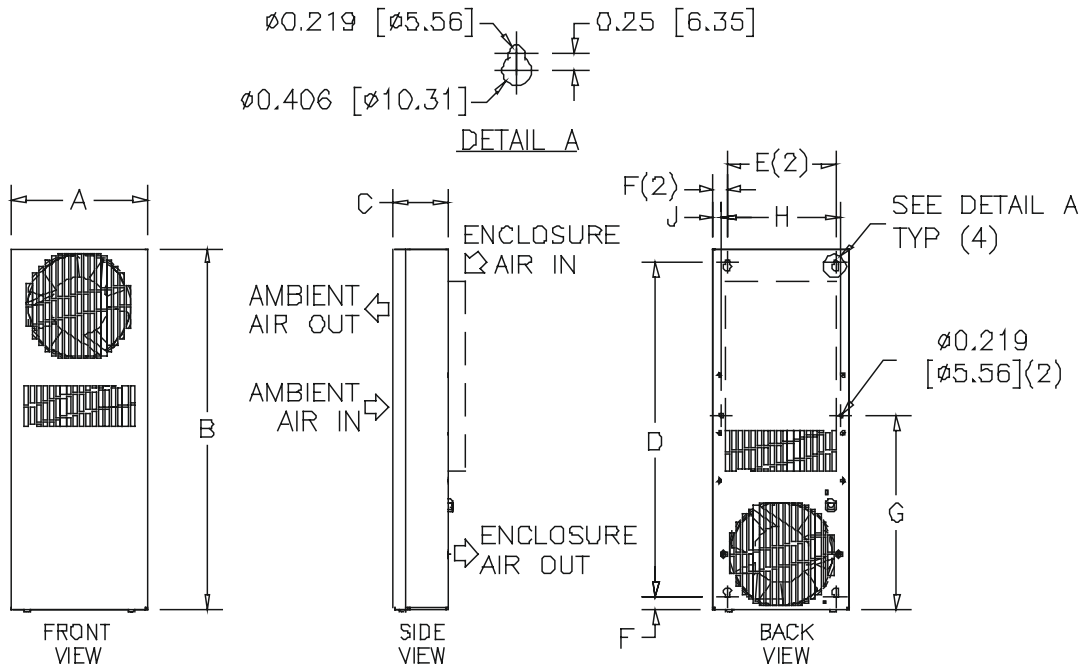

XR20-04 / XR29-08

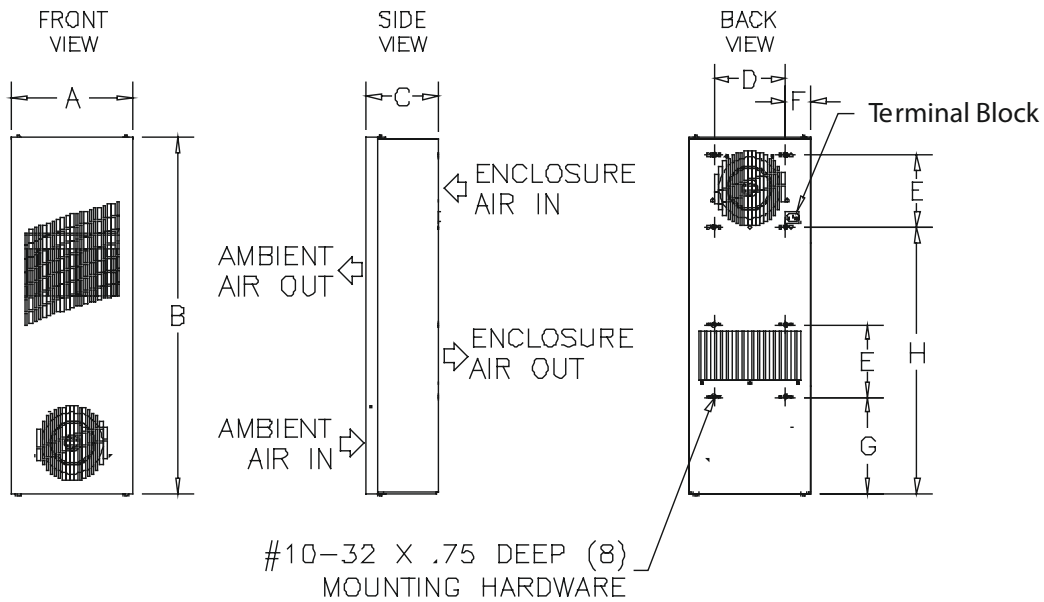

XR29-18 / XR47-24

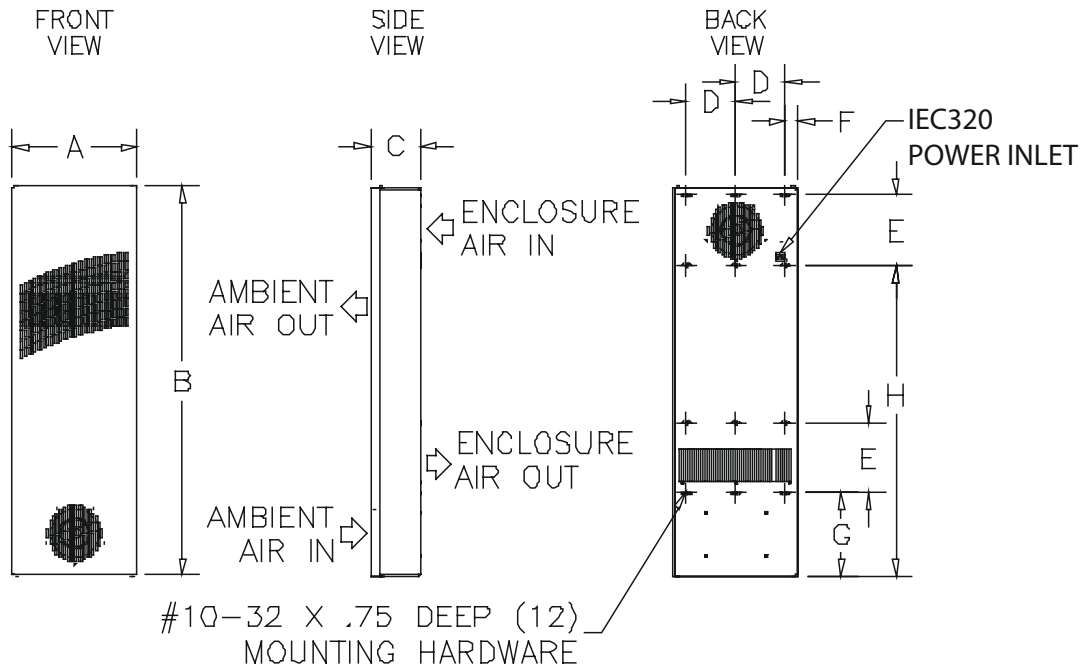

XR47-35 / XR60-55 / XR60-84

**DRAWING VARIABLES**

Model	A in. (mm)	B in. (mm)	C in. (mm)	D in. (mm)	E in. (mm)	F in. (mm)	G in. (mm)	H in. (mm)	J in. (mm)
XR20-0416-012 XR20-0426-012	7.50 (190.5)	20.00 (508.0)	3.00 (76.2)	18.50 (469.9)	6.00 (152.4)	.75 (19.1)	10.75 (273.1)	6.63 (168.4)	.44 (11.1)
XR29-0816-012 XR29-0826-012	10.00 (254.0)	29.50 (749.3)	3.10 (78.7)	27.50 (698.5)	8.00 (203.2)	1.00 (25.4)	14.75 (374.7)	8.00 (203.2)	1.00 (25.4)
XR29-1816-012 XR29-1826-012	10.24 (260.1)	29.66 (753.4)	5.92 (150.4)	6.00 (152.4)	6.00 (152.4)	2.08 (52.8)	8.08 (205.2)	22.20 (564.0)	22.44 (570.0)
XR47-2416-012 XR47-2426-012	10.24 (260.1)	47.16 (1197.9)	5.92 (150.4)	7.00 (177.8)	8.50 (215.9)	1.58 (40.1)	10.08 (256.0)	37.71 (957.8)	38.04 (966.2)
XR47-3516-012 XR47-3526-012	15.24 (387.1)	47.16 (1197.9)	5.92 (150.4)	6.00 (152.4)	8.50 (215.9)	1.58 (40.1)	10.08 (256.0)	37.71 (957.8)	38.04 (966.2)
XR60-5516-012 XR60-5526-012	15.24 (387.1)	59.66 (1515.4)	5.92 (150.4)	6.00 (152.4)	10.75 (273.1)	1.58 (40.1)	20.83 (275.1)	48.08 (1221.2)	48.66 (1235.8)
XR60-8416-012 XR60-8426-012	15.24 (387.1)	59.66 (1515.4)	9.92 (252.0)	6.00 (152.4)	10.75 (273.1)	1.58 (40.1)	20.83 (275.1)	48.08 (1221.2)	48.66 (1235.8)

# CUTOUTS

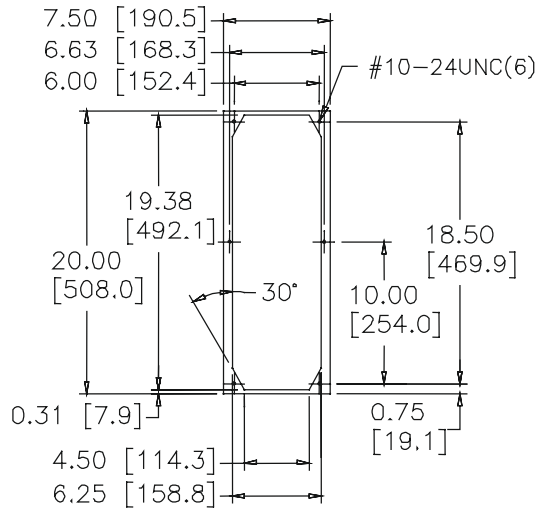

**XR20-04**

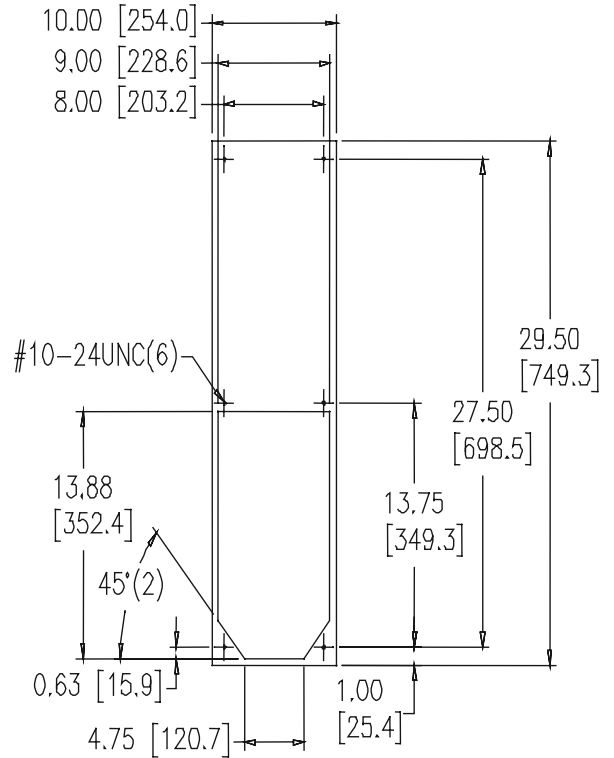

**XR29-08**

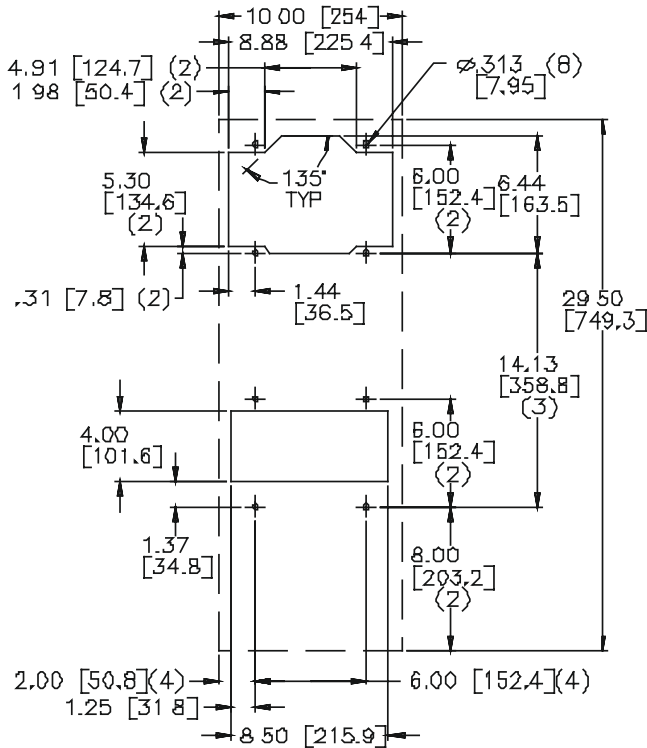

**XR29-18**

**NOTE:**

1. Dashed lines represent heat exchanger.

# CUTOUTS

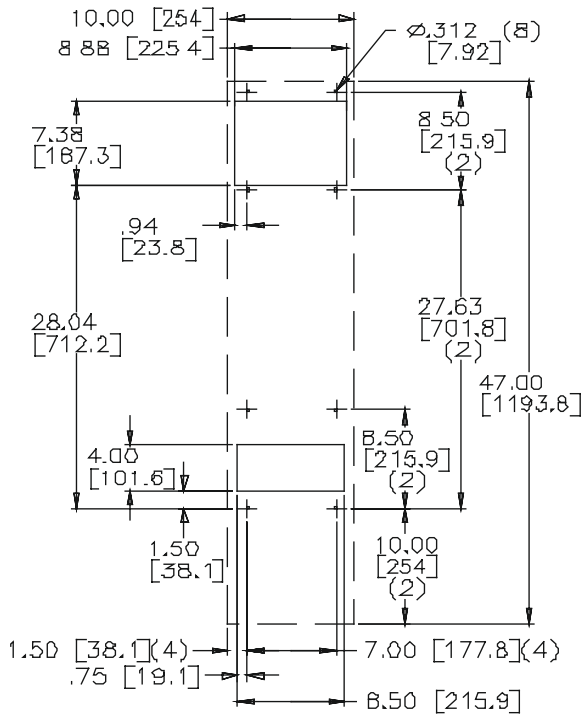

**XR47-24**

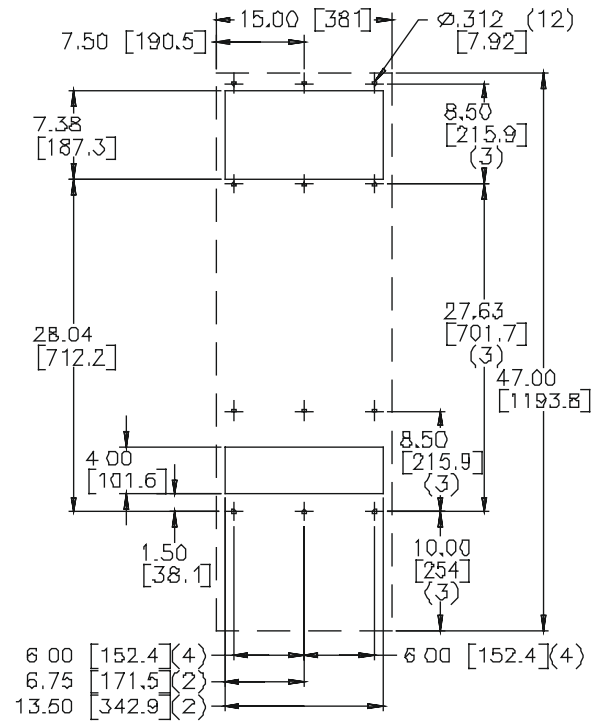

**XR47-35**

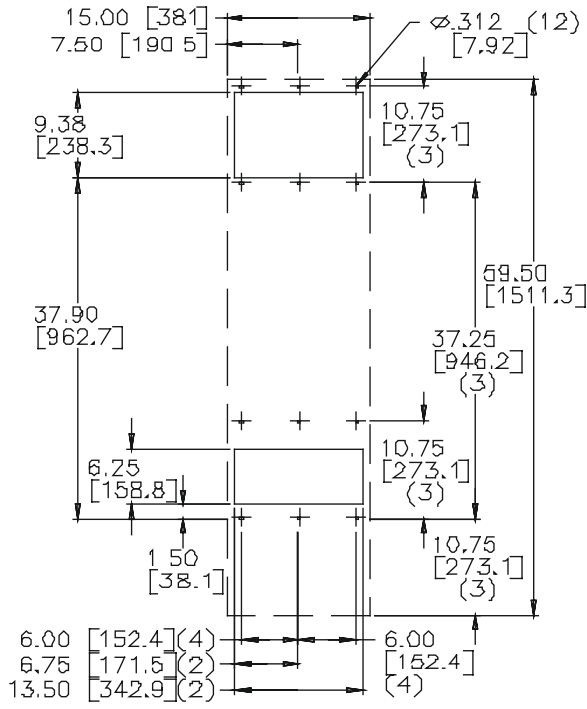

XR60 CUTOUT

**XR60-55 / XR60-84**







+44 (0)121 544 6808

| [info@cnet-is.co.uk](mailto:info@cnet-is.co.uk)

**C-NET Industrial Solutions  
Limited**

Suite 12, Sandwell Business Centre  
Oldbury Road  
Smethwick  
B66 1NN  
United Kingdom